

**Achtung:** The result of the rolling process has to be checked on the basis of the reference dimensions in this  
**Attention:** roller plan. Please note the examination advices of the current roller manual

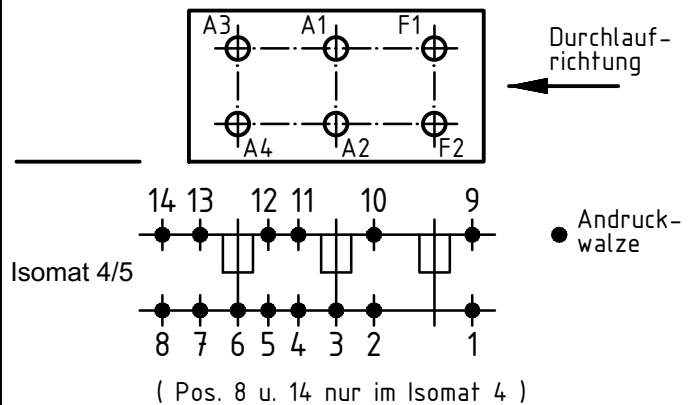
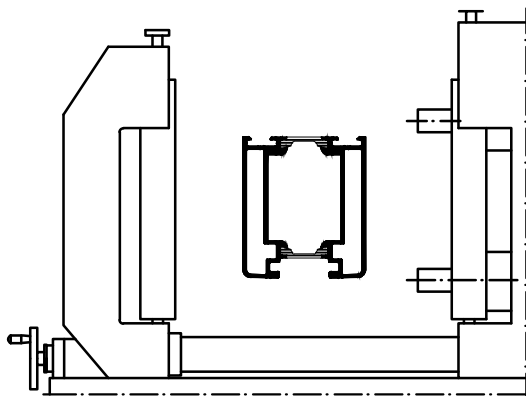

Stk. Qty.	Art.-Nr. Art.-No. für Isomat 5	Art.-Nr. Art.-No. für Isomat 4	Bestückungsfolge (v. innen nach außen) Assembly sequence (inside to outside)	Stk. Qty.	Art.-Nr. Zubehör Art.-No. Accessories
				R1	6
R2	6	296210 (10.0 mm)			
A1	1	282473 B	R1/A1/R2		
A2	1	282473 B	R1/A2/R2		
A3	1	282474 B	R1/A3/R2		
A4	1	282474 B	R1/A4/R2		
F1	1	282472 B	R1/F1/R2		
F2	1	282472 B	R1/F2/R2		

Zulässige Abweichung Permissible tolerance		Oberflächenabwicklung Circumference		VP PU	Info-Plan:
		mech. polished uml. total		Maßstab Scale	Gewicht Weight
Paßmaße Close tol.		Abmaße Std. tolerance		Werkstoff Material	
Original / Änderung Revision / Version		Datum Date	Name		Benennung Title
0100		25.06.2018	Finkemeyer, C. Winkler, A. Nienhüser, R.		
				510090 RP 1000	
		<b>SCHÜCO</b>		EDV erstellt Ohne Unterschrift gültig generated by EDP valid without signature	
				Ersatz für Replacement for	