

Achtung: The result of the rolling process has to be checked on the basis of the reference dimensions in this roller plan. Please note the examination advices of the current roller manual

Attention:

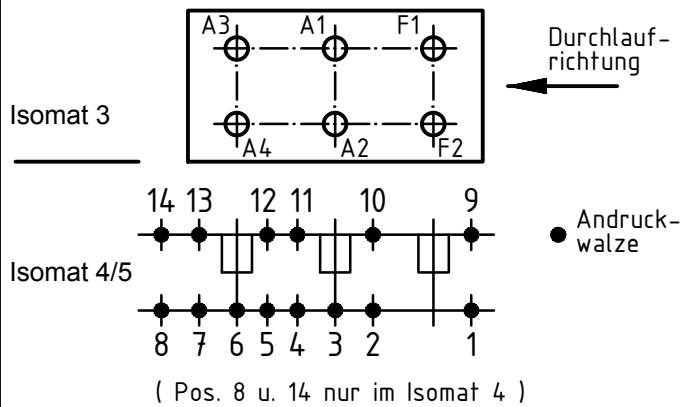
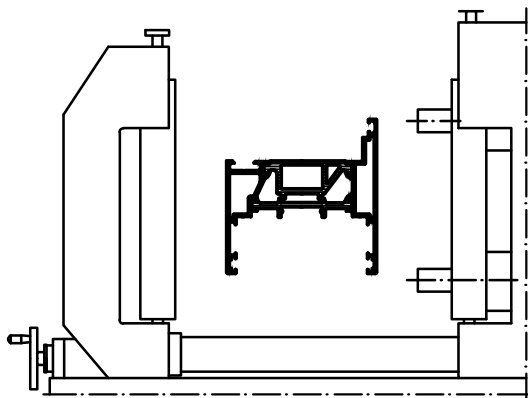

Stck. Qty.	Art.-Nr. Art.-No. für Isomat 3/5	Art.-Nr. Art.-No. für Isomat 4	Bestückungsfolge (v. innen nach außen) Assembly sequence (inside to outside)	Stck. Art.-Nr. Zubehör	
				Qty.	Art.-No. Accessories
A1	1	264063	264063	R1/A1	
A2	1	264061	264061	R1/A2	
A3	1	264064	264063	R1/A3	
A4	1	264062	264061	R1/A4	
F1	1	264059			
F2	1	264060			
R1	4				280743 (5.0 mm)

Zulässige Abweichung Permissible tolerance		Oberflächenabwicklung Circumference		VP PU	Info-Plan:
		mech. polished —		Maßstab Scale 1 : 1	Gewicht Weight
Paßmaße Close tol.		Abmaße Std. tolerance		Werkstoff Material	
Original / Änderung Revision / Version 0100		Datum Date 21.05.2019		Name	
Name		gez. drawn Finkemeyer, C.		Benennung Title Roller plan Isomat 3/4/5	
		gepr. checked Winkler, A.		Schüco ASE 80	
		ges. seen Nienhüser, R.		Zechn.-Nr. Drawing No. 519693 RP 0000	
		SCHÜCO		EDV erstellt Ohne Unterschrift gültig generated by EDP valid without signature	
				Ersatz für Replacement for	

Technical data subject to change. © Schüco International KG, Bielefeld, Germany. All Rights Reserved.
 Technische Änderungen vorbehalten. © Schüco International KG, Bielefeld, Germany. Alle Rechte vorbehalten.