

Achtung: The result of the rolling process has to be checked on the basis of the reference dimensions in this roller plan. Please note the examination advices of the current guidelines
Attention:

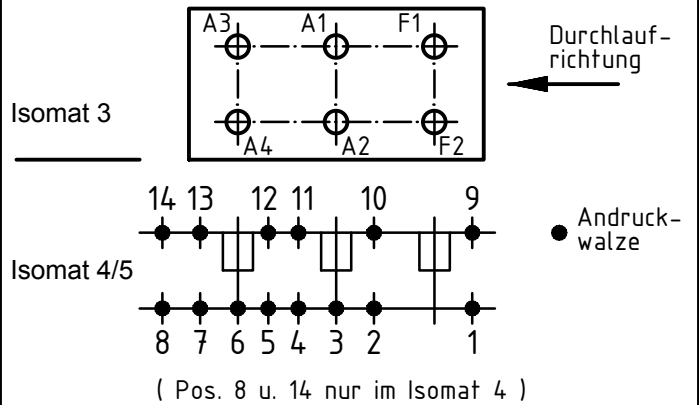
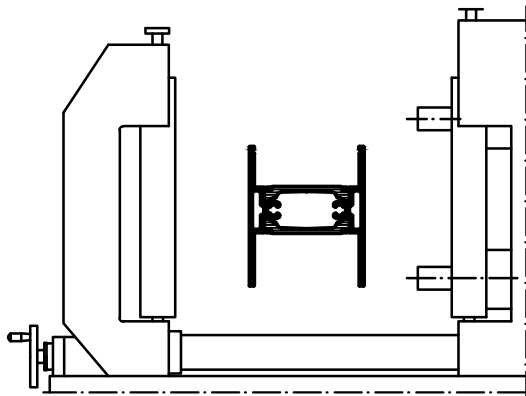

Stck. Qty.	Art.-Nr. Art.-No. für Isomat 3/5	Art.-Nr. Art.-No. für Isomat 4	Bestückungsfolge (v. innen nach außen) Assembly sequence (inside to outside)	Stck. Qty.	Art.-Nr. Zubehör Art.-No. Accessories
				R1	6
A1	1	280736 B	280736 B	R1/R2/A1/R3	
A2	1	280736 B	280736 B	R1/R2/A2/R3	
A3	1	280737 B	280736 B	R1/R2/A3/R3	
A4	1	280737 B	280736 B	R1/R2/A4/R3	
F1	1	280738 B		R1/R2/F1/R3	
F2	1	280738 B		R1/R2/F2/R3	

Zulässige Abweichung Permissible tolerance		Oberflächenabwicklung Circumference		VP PU	Info-Plan:
		mech. polished uml. total		Maßstab Scale	Gewicht Weight
				1 : 1	
Paßmaße Close tol.	Abmaße Std. tolerance	Original / Änderung Revision / Version		Werkstoff Material	
0100		Datum Date	Name	Benennung Title	
		29.06.2020	Finkemeyer, C. Winkler, A. Nienhüser, R.	Roller plan Isomat 3/4/5 Schüco ASE 51 PD	
		Zeichn.-Nr. Drawing No.		534000 RP 1000	
		EDV erstellt Ohne Unterschrift gültig generated by EDP valid without signature		Ersatz für Replacement for	
		SCHÜCO			