

Achtung: The result of the rolling process has to be checked on the basis of the reference dimensions in this roller plan. Please note the examination advices of the current guidelines
Attention:

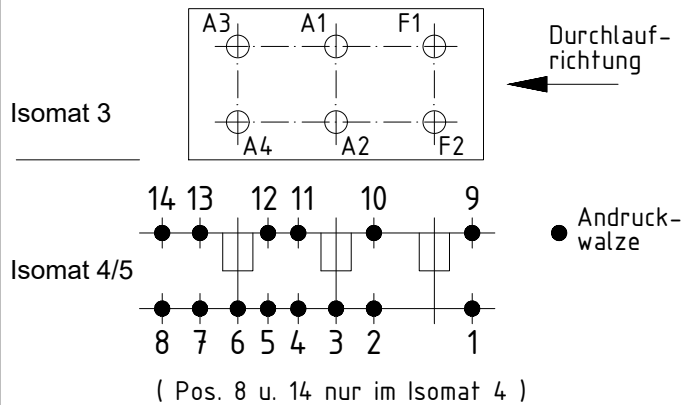
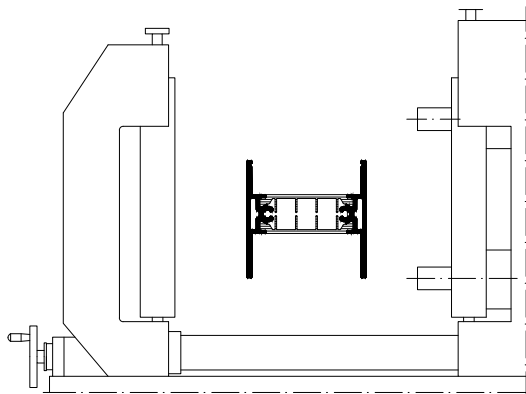

	Stck. Qty.	Art.-Nr. Art.-No.	Art.-Nr. Art.-No.	Bestückungsfolge (v. innen nach außen) Assembly sequence (inside to outside)	Zubehör Accessories	
					Stck. Qty.	Art.-Nr. Art.-No.
		Isomat 3/5	Isomat 4		R1	6 296209 (6.5 mm)
A1	1	283318 B	283318 B	R1/A1		
A2	1	283318 B	283318 B	R1/A2		
A3	1	283319 B	283318 B	R1/A3		
A4	1	283319 B	283318 B	R1/A4		
F1	1	283317 B		R1/F1		
F2	1	283317 B		R1/F2		

Zulässige Abweichung Permissible tolerance		Oberflächenabwicklung Circumference		VP PU	Info-Plan:
		mech. polished uml. total		Maßstab Scale	Gewicht Weight
				1 : 1	
Paßmaße Close tol.	Abmaße Std. tolerance	Datum Date		Werkstoff Material	Benennung Title
Original / Änderung Revision / Version		31.07.2024		Roller plan Isomat 3/4/5	
Name		Winkler, A. Morbato, A. Fatticcioni, L.		Schüco AS PD 63	
		31.07.2024		534480 RP 1000	
		SCHÜCO		EDV erstellt Ohne Unterschrift gültig generated by EDP valid without signature	
				Ersatz für Replacement for	